

PLAN

NEW GUTTER MUST BE POURED MONOLITHIC WITH ALL NEW DRIVEWAY APPROACHES

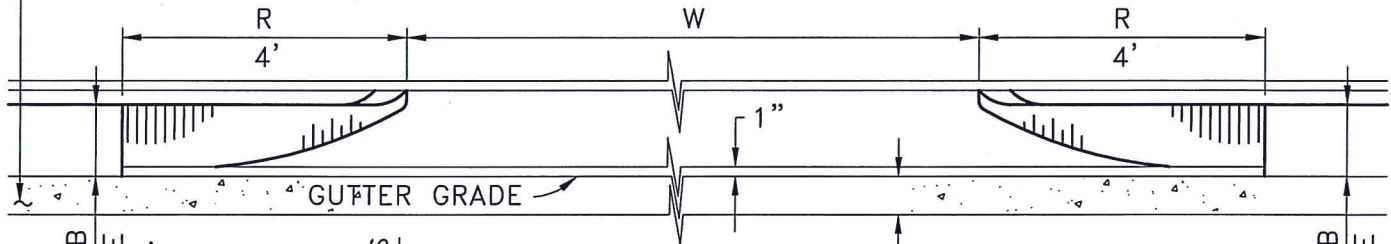

ELEVATION

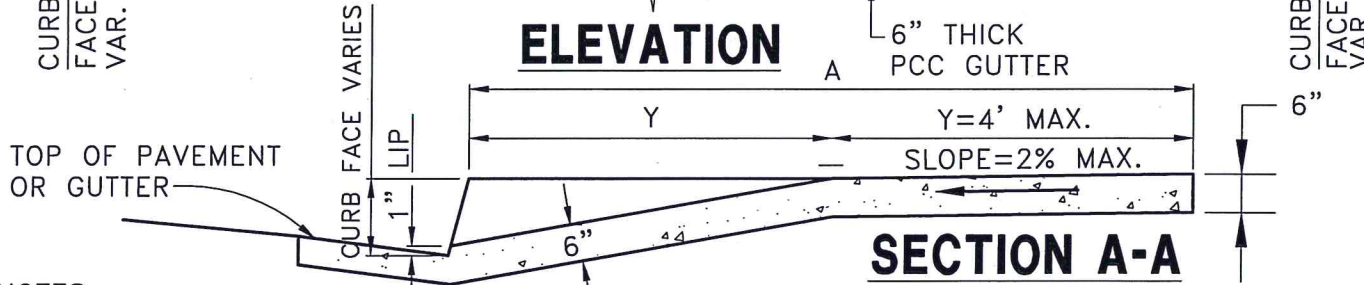

SECTION A-A

NOTES:

1. ALL WORK SHALL BE DONE IN ACCORDANCE WITH "STANDARD SPECIFICATIONS FOR PUBLIC WORKS CONSTRUCTION," LATEST EDITION.
2. THIS STANDARD MAY BE USED ONLY IN SPECIFIC HISTORICAL AREAS AND IF EXISTING OBJECTS INTERFERE WITH CONSTRUCTION USING DUSTPAN TYPE DESIGN PER CITY OF PASADENA STANDARD PLAN S-403.
3. STANDARD CURB RETURN RADIUS "R" EQUALS 4', "Y" SHALL NOT BE GREATER THAN "P" WITHOUT APPROVAL OF THE ENGINEER.
4. "W" SHALL BE AT LEAST 12' AND NO GREATER THAN 18' FOR RESIDENTIAL DRIVEWAYS OR 26' FOR COMMERCIAL DRIVEWAYS (EXCEPT IN SPECIAL CASES).
5. JOINTS, SCORING AND CONCRETE SPECIFICATIONS PER STD. PLAN S-421.

CITY OF PASADENA - DEPARTMENT OF PUBLIC WORKS

DRAWN BY:
ANDREW CLAYTON

CHECKED BY:
SEAN SINGLETARY

SUBMITTED BY:
CATHY CHANG

**DRIVEWAY-CURB
RETURN TYPE**

APPROVED BY:
Steve A. Wight
CITY ENGINEER RCE NO. 48650 EXPIRES JUNE 30, 2016

12/14/15
DATE

REVISION: 4 UNITS: ENG.

STANDARD PLAN:
S-402

SHEET 1 OF 2
S402-1-REV4.DWG 10/28/15

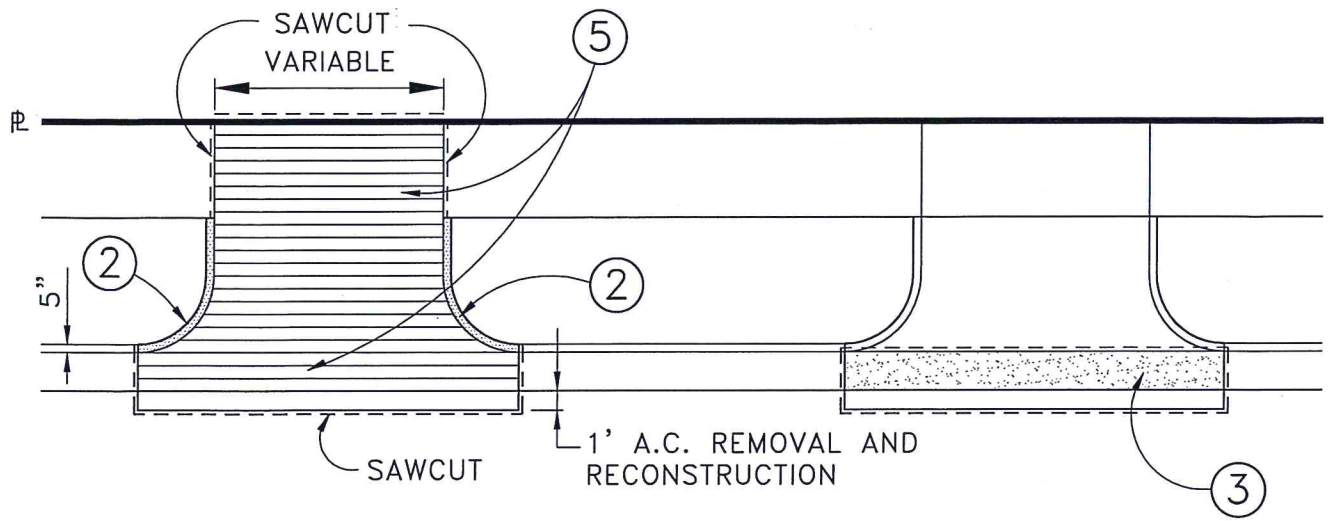

LEGEND

- ② REMOVE AND RECONSTRUCT VARIABLE HEIGHT PCC CURB ONLY.
- ③ REMOVE AND RECONSTRUCT PCC GUTTER ONLY.
- ⑤ REMOVE AND RECONSTRUCT 6" PCC DRIVE APRON.

REMOVAL AND RECONSTRUCTION OF TYPICAL CURB TYPE DRIVEWAY

NO SCALE

CITY OF PASADENA - DEPARTMENT OF PUBLIC WORKS

DRAWN BY:
ANDREW CLAYTON

CHECKED BY:
SEAN SINGLETARY

SUBMITTED BY
CATHY CHANG

DRIVEWAY-CURB RETURN TYPE

APPROVED BY:

Steve A. Wight
CITY ENGINEER RCE NO. 48650 EXPIRES JUNE 30, 2016

REVISION:

-

UNITS:

ENG.

STANDARD PLAN:

S-402

SHEET 2 OF 2
S402-2-0.DWG 10/28/15

12/14/15
DATE