

**PLAN**

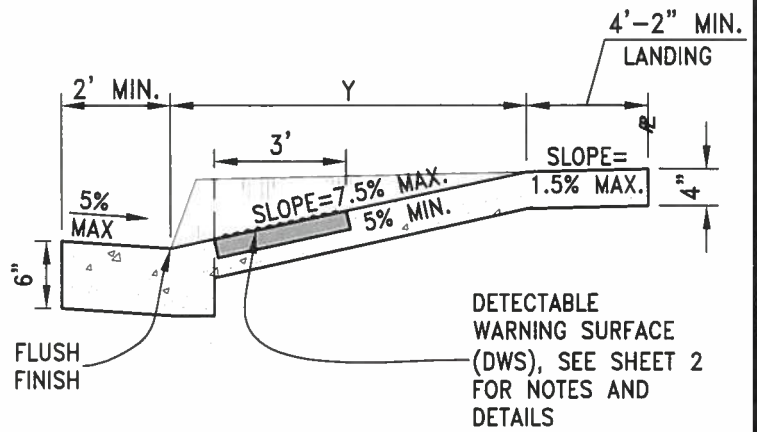

**SECTION A-A**

**CURB RAMP NOTES:**

1. TRANSITIONS FROM RAMPS TO WALKS, GUTTERS OR STREETS SHALL BE FLUSH AND FREE OF ABRUPT CHANGES.
2. MAXIMUM SLOPES OF ADJOINING GUTTERS, THE ROAD SURFACE IMMEDIATELY ADJACENT TO THE CURB RAMP AND CONTINUOUS PASSAGE TO THE CURB RAMP SHALL NOT EXCEED 5% WITHIN 4' OF THE BOTTOM OF THE CURB RAMP.
3. IF DISTANCE FROM CURB TO BACK OF SIDEWALK IS NOT SUFFICIENT TO ACCOMMODATE RAMP WITH A MAXIMUM 7.5% SLOPE AND 4'-2" MINIMUM LANDING, THE SIDEWALK MAY BE DEPRESSED LONGITUDINALLY WITH A RETAINING CURB AT THE BACK OF SIDEWALK IF FEASIBLE; HOWEVER, RETAINING CURBS SHALL NOT BE CONSTRUCTED WITHOUT THE APPROVAL OF THE CITY ENGINEER.
4. CURB RAMPS SHALL HAVE A DETECTABLE WARNING SURFACE THAT MEASURES 3' IN THE PEDESTRIAN DIRECTION OF TRAVEL AND EXTENDS THE FULL WIDTH OF THE RAMP. DETECTABLE WARNING SURFACES SHALL BE POLYMER COMPOSITE MATERIAL, YELLOW IN COLOR AND SHALL CONFORM TO THE DETAILS AS SHOWN ON SHEET 2 OF THIS STANDARD PLAN.
5. UTILITY MANHOLES, VENTS AND VAULTS WITHIN THE BOUNDARIES OF THE CURB RAMP SHALL BE RELOCATED OUTSIDE THE LIMITS OF THE RAMP AREA PRIOR TO, OR IN CONJUNCTION WITH, CURB RAMP CONSTRUCTION. THE CONTRACTOR IS RESPONSIBLE FOR COORDINATING THIS WORK WITH THE UTILITY OWNER.
6. PULL BOXES AND CONDUITS WITHIN THE BOUNDARIES OF THE CURB RAMP SHALL BE RELOCATED OUTSIDE THE LIMITS OF THE RAMP AREA. EXISTING WIRING SHALL BE PROTECTED AND REINSTALLED.

**CITY OF PASADENA - DEPARTMENT OF PUBLIC WORKS**

DRAWN BY:  
**ANDREW CLAYTON**

CHECKED BY:  
**CATHY CHANG**

SUBMITTED BY:  
**SEAN SINGLETARY**

**INTERSECTION CURB RAMP**

APPROVED BY:  
*Steve D. Wight*  
CITY ENGINEER LICENSE No. 48650 EXPIRES JUNE 30, 2016

**8/26/15**  
DATE

REVISION: 5 UNITS: ENG.

STANDARD PLAN:  
**S-414**  
SHEET 1 OF 2  
S414-1-REV8.DWG 8/5/15

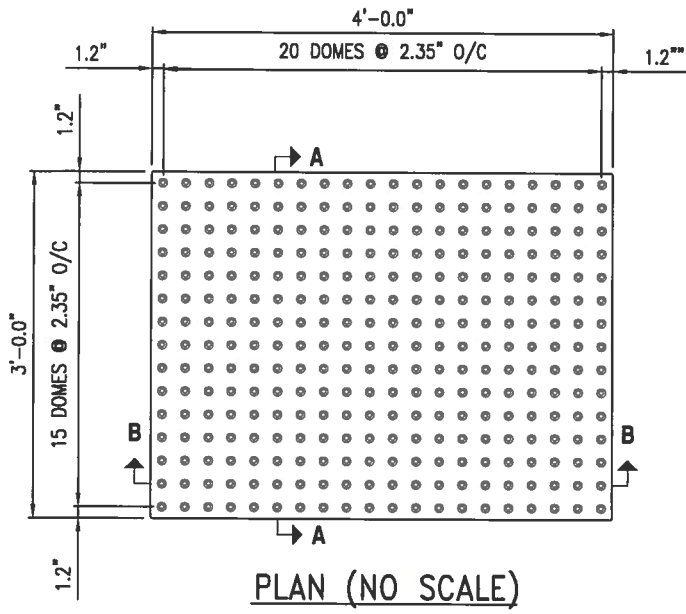

PLAN (NO SCALE)

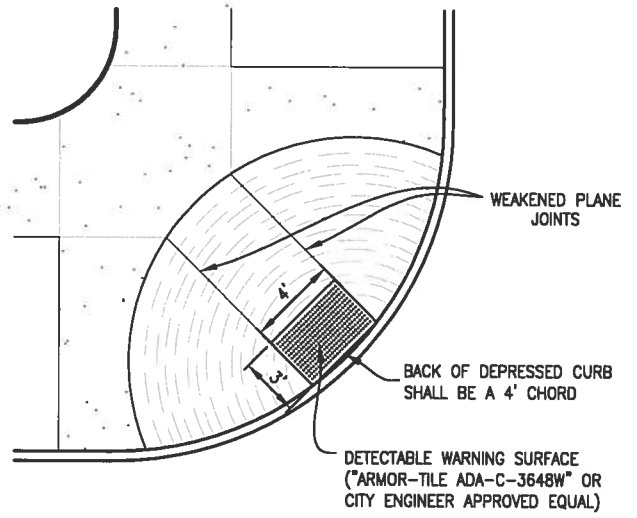

EMBEDDED DETECTABLE WARNING TILE FOR NEW CURB RAMP  
NOT TO SCALE

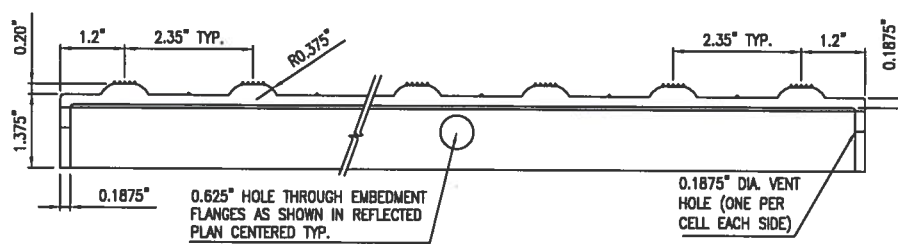

SECTION A-A

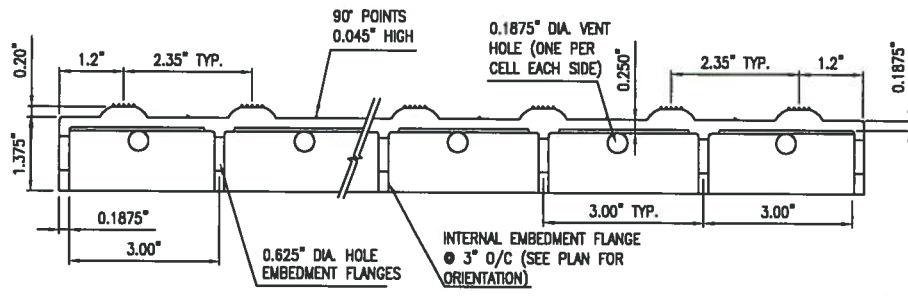

SECTION B-B

CITY OF PASADENA - DEPARTMENT OF PUBLIC WORKS

DRAWN BY:  
ANDREW CLAYTON

CHECKED BY:  
CATHY CHANG

SUBMITTED BY:  
SEAN SINGLETARY

INTERSECTION CURB RAMP

APPROVED BY:  
*Stan A. Wight*  
CITY ENGINEER LICENSE No. 48650 EXPIRES JUNE 30, 2016

8/26/15  
DATE

REVISION: 5 UNITS: ENG.

STANDARD PLAN:  
**S-414**

SHEET 2 OF 2  
S414-2-REVL.DWG 8/3/15